

# Bronze Rotary Gear Pumps

## Installation, Operation, and Maintenance Instruction



**OBERDORFER PUMPS**

by Gardner Denver

### TROUBLESHOOTING MATRIX

DIFFICULTY	PROBABLE CAUSE	REMEDY
No Liquid Delivery	<ol style="list-style-type: none"> <li>1) Closed valves</li> <li>2) Plugged suction</li> <li>3) Air leak at suction</li> <li>4) Suction lift too high</li> <li>5) Motor wired incorrectly</li> <li>6) Wrong rotation</li> </ol>	<ol style="list-style-type: none"> <li>1) Open valves</li> <li>2) Eliminate restriction</li> <li>3) Locate and repair leak</li> <li>4) Do not exceed vapor pressure of liquid</li> <li>5) Check wiring diagram</li> <li>6) Correct rotation</li> </ol>
Low Liquid Delivery	<ol style="list-style-type: none"> <li>1) Pump shaft speed incorrect</li> <li>2) Discharge pressure too high</li> <li>3) Air leak at suction</li> <li>4) Worn or damaged pump</li> <li>5) Low viscosity</li> </ol>	<ol style="list-style-type: none"> <li>1) Check driver speed, motor wiring, pulley tension</li> <li>2) Reduce downstream pressure</li> <li>3) Locate and repair leak</li> <li>4) Inspect and repair as required</li> <li>5) Verify original application conditions</li> </ol>
Gradually Loses Prime	<ol style="list-style-type: none"> <li>1) Suction lift too high</li> <li>2) Air or gas in fluid</li> <li>3) Air leak at suction</li> <li>4) Worn or damaged pump</li> </ol>	<ol style="list-style-type: none"> <li>1) Improve suction pressure</li> <li>2) Eliminate air or gas from fluid</li> <li>3) Locate and repair leak</li> <li>4) Inspect and repair as required</li> </ol>
Noisy	<ol style="list-style-type: none"> <li>1) Cavitating</li> <li>2) Solid particles in fluid</li> <li>3) Air or gas in fluid</li> <li>4) Worn or damaged pump</li> </ol>	<ol style="list-style-type: none"> <li>1) Improve system suction pressure, provide adequate NPSH</li> <li>2) Install suction strainer. Clean suction strainer.</li> <li>3) Eliminate air or gas from fluid</li> <li>4) Inspect and repair as required</li> </ol>
Motor Runs Hot or Overloads	<ol style="list-style-type: none"> <li>1) Discharge pressure too high</li> <li>2) Shaft speed too fast</li> <li>3) Fluid viscosity higher than expected</li> <li>4) Incorrectly wired motor</li> <li>5) Binding internal pump parts</li> <li>6) Motors normally feel hot</li> </ol>	<ol style="list-style-type: none"> <li>1) Reduce downstream pressure. Check relief valve setting. Be sure discharge pressure gages function correctly.</li> <li>2) Reduce speed</li> <li>3) Change to larger horsepower or higher service factor motor. Thin fluid.</li> <li>4) Check wiring diagram</li> <li>5) Inspect and correct condition</li> <li>6) Verify if actual motor amperage draw is within range</li> </ol>
Seal Leaks	<ol style="list-style-type: none"> <li>1) Dry running</li> <li>2) Solids in fluids</li> <li>3) Damaged during field replacement</li> <li>4) Seal material incompatible with fluid</li> </ol>	<ol style="list-style-type: none"> <li>1) Open valves. Prime pump</li> <li>2) Add suction strainer</li> <li>3) Inspect and replace damaged components</li> <li>4) Verify original application conditions. Consult factory.</li> </ol>

# Bronze Rotary Gear Pumps Installation, Operation, and Maintenance Instruction

### INTRODUCTION

Congratulations for choosing an Oberdorfer pump, the Industry Standard for quality since 1890.

### Construction

High pressure accelerates wear. For longer service life keep pressure as low as possible.

### Application Range

Bronze Rotary Gear pumps are of the external gear positive displacement type, displacing a finite volume of fluid with each shaft revolution. As such, capacity varies in direct proportion to pump speed. They are suited to handle clear lubricating and non-lubricating fluids, with PH ranging from 4 to 11, and temperatures to 400F. These pumps handle viscous fluids to 100,000 cps (462000 SSU) at reduced shaft speeds, with flow rates to 175 GPM (662 LPM), differential pressures to 150 psig (10.3 BAR), and suction lift capability to 20 feet (6.1 meters) for new pumps.

### Field Inspection

Bronze Rotary Gear pumps may be readily inspected in the field usually without removal from the drive or system plumbing. Simply remove the cover screws to pull the cover. Before attempting an inspection, follow safety precautions and be sure to read and understand this manual.

### New Pump Receipt Inspection

Upon receipt, check for obvious shipping damage and completeness to purchase order requirements. Shortages or damage should be reported immediately to the carrier and to your Oberdorfer distributor. Occasionally during shipment, possible misalignment or other damage including cracked mechanical seal faces can occur. As such, customers are advised to test the pump with water in a convenient location prior to installing into the intended system.

### Construction

These instructions should be kept in a convenient location for ready reference. The manual should be read carefully by persons responsible for installation, operation, and maintenance of the equipment. For ease of reference, a copy of the order should be kept with the manual. Write down the pump model number as

shown on the pump name tag, and the date the unit was placed into service.

### INSTALLATION

#### Site Preparation

Choose a site that allows easy access to the pump for maintenance. Consider protection from the elements. Guard against drips and spray from nearby equipment. Choose a solid foundation for mounting. If noise is a concern, consider a rubber pad under the pump base to dampen.

#### Flow Direction

Gear pumps will perform equally well in either direction however care must be taken for pumps equipped with integral pressure relief valves. To change flow direction effectively reversing the suction and discharge ports, simply switch driver rotation by following motor wiring diagram instructions and change the location of the relief valve as shown below. Most pump motor units are factory supplied with counterclockwise shaft rotation (when viewing the pump from the shaft end).

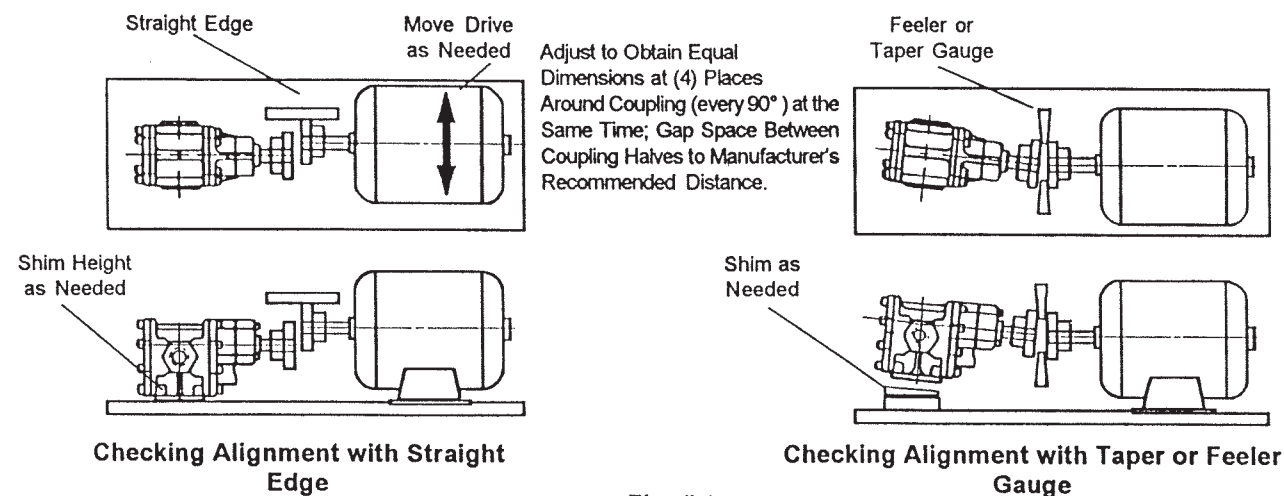
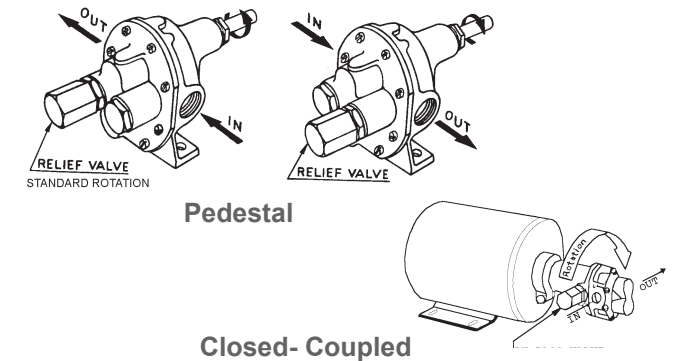

Fig. # 1



#### Suction Plumbing

Suction side plumbing considerations are key to desirable pump performance. Minimize head loss by assuring sufficient pipe size (especially important for highly viscous services). Generally the same size pipe as the pump ports is adequate. For long runs (beyond 3 feet) or viscous fluids, use one or two pipe sizes larger. Strive to keep the lines as short and straight as possible. If flexible lines are used, they should be selected to prevent wall collapse.



**OBERDORFER PUMPS**  
by Gardner Denver

5900 Firestone Drive, Syracuse, NY 13206

Phone: (800) 448-1668; (315) 437-0361 • Fax: (315) 463-9561

Visit [www.oberdorfer-pumps.com](http://www.oberdorfer-pumps.com) to find in-depth descriptions of the world's leading high-quality, dependable pumps.

Due to ongoing product improvements, data shown here is subject to change without notice. Contact Oberdorfer Pumps for latest specifications.

BronzeIOM.060514

## Bronze Rotary Gear Pumps Installation, Operation, and Maintenance Instruction

To keep the pump from being starved or running dry, be sure there is sufficient fluid supply. A flooded suction is generally preferred. Suction lifts over 3 vertical feet and long horizontal runs (beyond 3 lineal feet) require a foot or check valve below the level of the liquid being pumped. When taking suction from a tank or vessel, position the inlet above the maximum expected level of solids. Use full-bore ball valves or gate valves to minimize restriction. Suction strainers should be properly sized to minimize pressure drop and positioned for easy cleaning access. If start-up screens are used, be sure they are removed prior to placing the system into regular operation. Orient lines so as to prevent formation of air pockets. Be sure all joints are tight. Flush out all suction lines prior to installing the pump.

### General Piping

For further ease of maintenance, use union fittings to connect the pump to the system. Install a discharge priming tee for convenience. Do not spring the piping to connect the pump. Use piping supports or hangers as required. When necessary, provide for thermal expansion and contraction to avoid placing strain on the pump.

### Alignment

Proper alignment is key to seal and bearing performance. Improper alignment can lead to premature pump failure. Check the alignment carefully between the pump and the drive. (See Figure #1 on pg.4 for more information regarding Proper Alignment).

### Belt Drive

Though alignment is not as critical as direct connected, ensure that the pump and motor shafts are parallel and in line. For units suitable for belt drive, be sure that the belt tension is adequate (per the belt manufacturer's recommendation) but do not overtighten. For heavy pulley loads, models are equipped with external ball bearing supports. A single 1/2" (A or 4L section) V-belt is satisfactory for drive speeds up to 1 HP 3450 RPM. For larger drive sizes, double-V belts are recommended. Install guards around all moving parts in accordance with OSHA to prevent personal injury.

### Fasteners

Unless the pump has been shipped directly from the factory, it is recommended to check all bolts and nuts for tightness to eliminate possible leakage problems or destructive vibration

### Pressure Relief

Discharge lines should be fitted with properly sized line pressure relief valves to protect both the pump and the system. Pumps equipped with integral internal bypass relief valves are intended as a safety device against intermittent over-pressurization. They are not designed for continuous use and can lead to overheating. In these instances, a line pressure relief valve is required. The relief outlet should be piped back to the suction vessel.

### Flow By-Pass

When a flow by-pass system is used to control output from the pump, the bypassed fluid should be directed back to the suction vessel to avoid recirculation heat build-up. In cases where this is not possible, connect to the suction at least 10 pipe diameters length away from the pump inlet. Provisions for cooling should be made in the event of recirculation heat build-up.

### Pump Driver Mounting

Adapter kits (including bracket, coupling components, and hardware) are available for Bronze Close Coupled Gear pumps allowing connectivity to NEMA and IEC motor frames. Assembly instructions are included with each kit. Adapterless motors, carbonator mounts, and electric clutches are available for some models. Base mount kits (including baseplate, coupling components, coupling guard, and hardware) are available for Bronze Pedestal Gear pumps. Contact your Oberdorfer representative for additional information.

**WARNING**

**Follow National Electrical Code. Verify that electrical service is properly grounded, fused, and adequately sized for motor nameplate requirements. Check to be sure that motor wiring connections are correct referring to the wiring diagram on the motor nameplate or inside the terminal box.**

## OPERATION

### Pre-Startup

Prior to start-up, recheck installation as described above. Verify desired rotation by jogging the motor and make corrections if necessary. Before initial startup, pre-wet the gears and make sure the pump is adequately primed. Failure to do so could cause immediate damage to pump components. Make sure that discharge valves are open.

### Startup

Start pump and check for proper operation. Adjust packing (if applicable) as necessary, allowing adequate time to run in. Do not overtighten the packing else damage to the packing and the shaft can occur. A properly packed and adjusted packing nut will leak at about 10 drops every 3 to 5 minutes. Tighten packing nut only while shaft is rotating. Lip and mechanical seal versions require no adjustment. If the pump's bearing areas or seal area runs hot, shut the pump down and determine the cause. For units equipped with integral pressure relief valve, the factory setting is usually 50 psig. It is recommended that the setting should be 5 psig above the operating pressure in the discharge line. To increase the set point, turn the by-pass valve adjusting screw clockwise. If start-up screens were used, be sure they are removed prior to placing the system into regular operation. Depending on suction conditions, it may be necessary to reprime the pump for subsequent restarts.

**WARNING**

**Dry running leads to immediate damage to pump components. Due to tight running clearances, liquids containing solids and abrasives will accelerate pump wear. When possible, flush the pump after each usage. Allowing liquid to freeze in the pump can cause damage.**

## MAINTENANCE

### Frequency

Since each installation differs, the frequency and extent of pump maintenance is best established based upon past performance. Keeping detailed maintenance records of past performance aids in determining future preventative maintenance intervals. During routine operating inspections, pay particular attention to seal and bearing areas of the pump. Consult the motor manufacturer for motor maintenance instructions.

**WARNING**

**Before attempting to service the pump: Disconnect motor power and release all pressure within the system. Flush the pump thoroughly with a neutralizing fluid before attempting to disassemble. Wear appropriate personal protection equipment and handle the equipment with care.**

### Changing Applications

Verify that all wetted parts of the pump are compatible with the new fluid to be handled and that the motor is

adequately sized. Check with your Oberdorfer distributor if in doubt.

### Inspect for Wear

If your Bronze Gear Pump exhibits reduced flow, an inability to maintain pressure, is noisy or performs otherwise abnormally, first refer to the Troubleshooting Matrix on back. If the problem persists, the pump should be inspected for wear or damage. Oberdorfer Bronze Gear pump internals may be readily inspected in the field usually without removal from the drive or system plumbing. Simply remove the cover screws to pull the cover. Full pump removal and complete disassembly may be needed for a comprehensive inspection. Contact your local authorized distributor or the Oberdorfer factory.

### Mechanical Seals

Pumps equipped with mechanical seals are of the standard pusher bellows type or wedge style. They can be expected to provide long and trouble free service provided:

- 1) Seal materials are compatible with pumped fluid and properly applied to the service.
- 2) Adequate cooling and lubrication is provided
- 3) Dry running is avoided
- 4) Abrasives are kept away from the seal area
- 5) Pump and driver are properly aligned

Detailed mechanical seal inspection and replacement instructions are included with Oberdorfer Repair Kits.

### Lip Seals

Pumps equipped with lip seals are of the metal cased, spring energized, single lip style. These are intended to provide minimum friction drag with positive sealing and again should be maintenance free provided the same conditions for mechanical seals are met as well as:

- 6) Avoid scouring of the shaft in the lip seal area due to contaminated abrasives
- 7) Avoid excessive seal lip contact pressure on the pump shaft due to excessive pump pressure.

These are readily replaceable by pressing out the old seal and pressing in a new replacement.

### Packing

Pumps equipped with teflon or graphoil packing require periodic adjustment as described above in the Startup section to avoid excessive leakage. Eventually all the packing in the pump will become deteriorated and will have to be replaced.

### Recommended Spares

Repair kits are available for all Oberdorfer Bronze Gear Pumps. Each kit comes with detailed instructions. For the proper kit, contact your Oberdorfer Distributor or the factory.



N999, N991  
N992, N993



N994, N970  
N990



N13 Series

Pedestal Gear

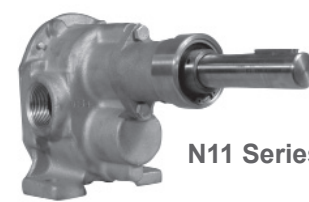

N11 Series



N26 Series



Carbonator

Clutch Driven

